

NEW

20 W XENON FLASH LAMP MODULES

L12745 SERIES

OVERVIEW

The L12745 series is a 20 W xenon flash lamp module integrated with a regulated drive power supply and a lamp trigger socket. The light-emitting point of the lamp is preadjusted and that means there is no need of optical axis adjustment after wiring and lamp installation. Therefore the L12745 series can be used by just installing it into equipment. This unit includes proven high performance lamp and delivers high stability, high repetition rate and long life.

This unit can be used in wide range applications such as analysis which needs high repetition rate and light sources for imaging /photo excitation which needs high output.



FEATURES

- Compact: 148 mm × 97 mm × 52 mm
- High stability: 0.5 % CV (Typ.)
- High output: 500 mJ input (Max.)
- High repetition rate: 1000 Hz (Max.)

APPLICATIONS

- Blood analysis (MTP reader, etc.)
- Fluorescence analysis
- Semiconductor inspection
- Light sources for imaging
- Environmental analysis

EMISSION PULSE WAVEFORM

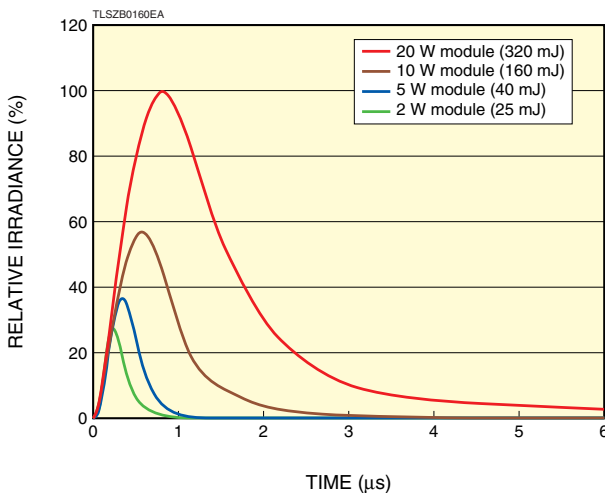

LIFE CHARACTERISTICS

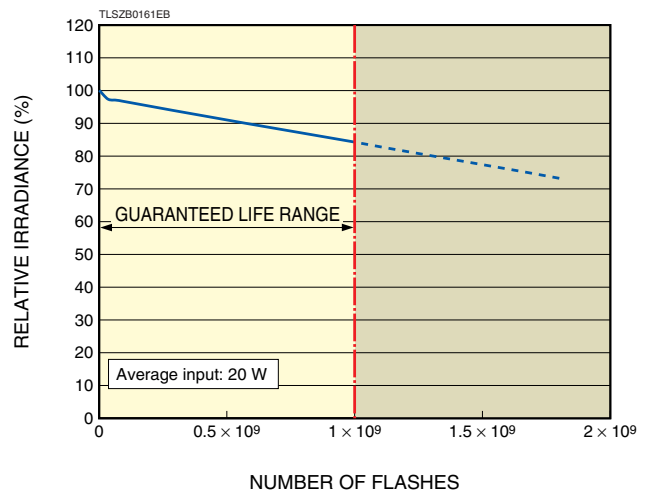

1.0 × 10⁹ flashes = 2777 h with 100 Hz operation.

SPECIFICATIONS

| Parameter | L12745-01 | L12745-02 | L12745-03 | Unit |
|---------------------------------------|--|-----------|-----------|---------|
| Arc size | 1.5 | | | mm |
| Window material | UV glass | | | — |
| Spectral distribution | 185 to 2000 | | | nm |
| Main discharge voltage range *1 | 400 to 1000 | | | V |
| Main discharge capacitor | 0.64 | 0.32 | 0.1 | μF |
| Maximum input energy (per flash) *2 | See operation conditions. | | | — |
| Maximum average input (continuous) *3 | 20 | | | W |
| Light output stability (Max.) *4 | 2.0 | | | % CV |
| Guaranteed life *5 | 1 × 10 ⁹ | | | flashes |
| Input voltage | 21.6 to 26.4 | | | V |
| Input current | 1.5 | | | A |
| Inrush current | 3 | | | A |
| Trigger input | Rectangular wave 2.5 V to 10 V: pulse width must be 10 μs or more. *6 | | | — |
| Trigger input impedance | 330 | | | Ω |
| Cooling method | Not required *7 | | | — |
| Operating temperature range | 0 to 40 | | | °C |
| Storage temperature range | -40 to +90 | | | °C |
| Operating humidity range | Below 85 (no condensation) | | | % RH |
| Storage humidity range | Below 95 (no condensation) | | | % RH |
| EMC standards | IEC61326-1: 2012 Group1, ClassA | | | — |
| Safety standards | IEC61010-1: 2010 IEC62471: 2006 Risk Group3 | | | — |

NOTE:

- *1 Internal: Adjustable with variable trimmer.
External: Variable with control voltage from 1.9 V to 4.76 V.
- *2 Maximum input energy (per flash)
 $E=1/2 CV^2$
E: Maximum input energy (J)
V: Main discharge capacitor (V)
C: Main discharge capacitance (F)
- *3 Maximum average input (continuous)
 $W=E \times f$
f: Repetition Rate (Hz)
- *4 Light output stability is given by:
Light output stability (% CV) =
light output standard deviation /
average light output × 100
- *5 At 20 W operation
- *6 Only for external control;
synchronized with rising edge.
- *7 Cooling is required when the
package temperature exceeds 50
°C during operation.

OPERATING CONDITIONS

| Type No. | Main discharge capacitor (μF) | Main discharge voltage (V) | Maximum input energy [per flash] (mJ) | Maximum repetition rate (Hz) | Maximum average input (W) |
|-----------|-------------------------------|----------------------------|---------------------------------------|------------------------------|---------------------------|
| L12745-01 | 0.64 | 400 | 51.2 | 391 | 20 |
| | | 500 | 80.0 | 250 | 20 |
| | | 700 | 156.8 | 128 | 20 |
| | | 1000 | 320.0 | 63 | 20 |
| L12745-02 | 0.32 | 400 | 25.6 | 781 | 20 |
| | | 500 | 40.0 | 500 | 20 |
| | | 700 | 78.4 | 255 | 20 |
| | | 1000 | 160.0 | 125 | 20 |
| L12745-03 | 0.1 | 400 | 8.0 | 1000 | 8 |
| | | 500 | 12.5 | 1000 | 12.5 |
| | | 700 | 24.5 | 816 | 20 |
| | | 1000 | 50.0 | 400 | 20 |

DIMENSIONAL OUTLINES (Unit: mm)

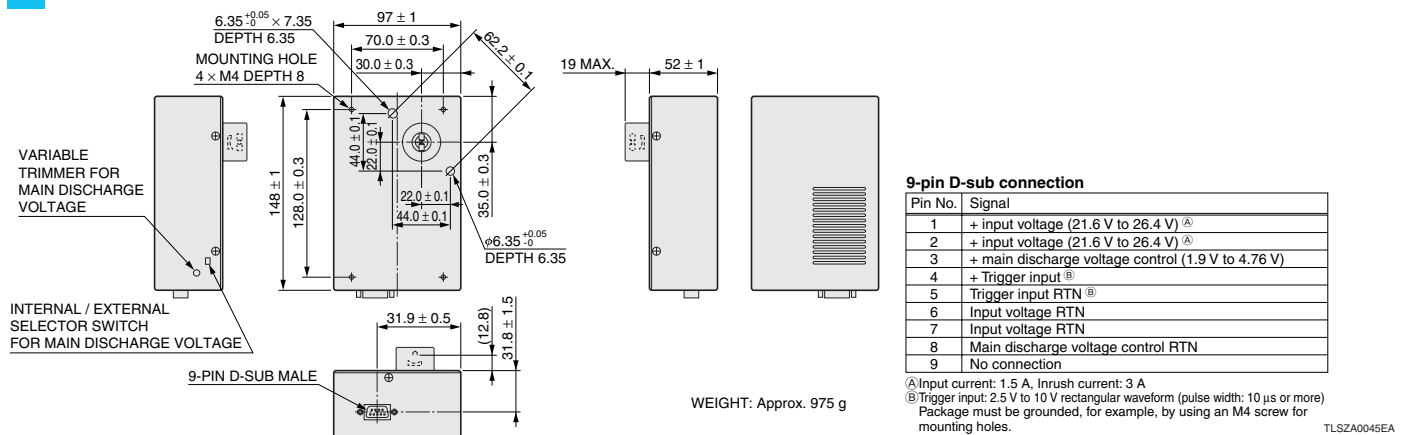

Subject to local technical requirements and regulations, availability of products included in this promotional material may vary. Please consult with our sales office.
 Information furnished by HAMAMATSU is believed to be reliable. However, no responsibility is assumed for possible inaccuracies or omissions. Specifications are subject to change without notice. No patent rights are granted to any of the circuits described herein. ©2016 Hamamatsu Photonics K.K.

HAMAMATSU PHOTONICS K.K. www.hamamatsu.com

HAMAMATSU PHOTONICS K.K., Electron Tube Division

314-5, Shimokanzo, Iwata City, Shizuoka Pref., 438-0193, Japan, Telephone: (81)539/62-5248, Fax: (81)539/62-2205

U.S.A.: Hamamatsu Corporation: 360 Foothill Road, Bridgewater, N.J. 08807-0910, U.S.A., Telephone: (1)908-231-0960, Fax: (1)908-231-1218 E-mail: usa@hamamatsu.com

Germany: Hamamatsu Photonics Deutschland GmbH: Arzbergerstr. 10, D-82211 Herrsching am Ammersee, Germany, Telephone: (49)8152-375-0, Fax: (49)8152-2658 E-mail: info@hamamatsu.de

France: Hamamatsu Photonics France S.A.R.L.: 19, Rue du Saule Trapu, Parc du Moulin de Massy, 91882 Massy Cedex, France, Telephone: (33)1 69 53 71 00, Fax: (33)1 69 53 71 10 E-mail: infos@hamamatsu.fr

United Kingdom: Hamamatsu Photonics UK Limited: 2 Howard Court, 10 Tewin Road, Welwyn Garden City, Hertfordshire AL7 1BW, United Kingdom, Telephone: (44)1707-294888, Fax: (44)1707-325777 E-mail: info@hamamatsu.co.uk

North Europe: Hamamatsu Photonics Norden AB: Torshamnsgatan 35 SE-164 40 Kista, Sweden, Telephone: (46)8-509-031-00, Fax: (46)8-509-031-01 E-mail: info@hamamatsu.se

Italy: Hamamatsu Photonics Italia S.r.l.: Strada della Moia, 1 int. 6, 20020 Arese (Milano), Italy, Telephone: (39)02-93581733, Fax: (39)02-93581741 E-mail: info@hamamatsu.it

China: Hamamatsu Photonics (China) Co., Ltd.: B1201 Jiaming Center, No.27 Dongsanhuan Beilu, Chaoyang District, Beijing 100020, China, Telephone: (86)10-6586-6006, Fax: (86)10-6586-2866 E-mail: hpc@hamamatsu.com.cn

TLSZ1029E02
FEB. 2016 IP